

## SOT<sub>INY</sub><sup>™</sup> Low Voltage Dual SPDT Analog Switch 2:1 Mux/DeMux Bus Switch

### Features

- CMOS Technology for Bus and Analog Applications
- Low On-Resistance: 8Ω at 3.0V
- Wide V<sub>CC</sub> Range: 1.65V to 5.5V
- Rail-to-Rail Signal Range
- Control Input Overvoltage Tolerance: 5.5V min.
- Fast Transition Speed: 5.2ns max. at 5V
- High Off Isolation: 57dB at 10MHz
- 54dB (10MHz) Crosstalk Rejection Reduces Signal Distortion
- ESD Protection 2kV HBM + 200V MM
- Break-Before-Make Switching
- High Bandwidth: 250 MHz
- Extended Industrial Temperature Range: -40°C to 85°C
- Packaging (Pb-free & Green available):  
-12-contact TDFN (ZA)

### Applications

- Cell Phones
- PDAs
- Portable Instrumentation
- Battery Powered Communications
- Computer Peripherals

### Pin Description

Pin Number	Name	Description
8, 11	<sub>1</sub> B <sub>X</sub>	Data port (Normally Open)
3, 6	GND	Ground
2, 5	<sub>0</sub> B <sub>X</sub>	Data port (Normally Closed)
1, 4	A <sub>X</sub>	Common Output/data port
9, 12	V <sub>CC</sub>	Positive Power Supply
7, 10	S <sub>X</sub>	Logic Control

#### Notes:

1. x = 0 or 1

### Logic Function Table

Logic Input(s)	Function
0	<sub>0</sub> B <sub>X</sub> Connection to A <sub>X</sub>
1	<sub>1</sub> B <sub>X</sub> Connected to A <sub>X</sub>

### Description

The PI5A3158 is a dual high-bandwidth, fast single-pole double-throw (SPDT) CMOS switch. It can be used as an analog switch or as a low-delay bus switch. Specified over a wide operating power supply voltage range, 1.65V to 5.5V, the PI5A3158 has a maximum On-Resistance of 12Ω at 1.65V, 9Ω at 2.3V & 6Ω at 4.5V.

Break-before-make switching prevents both switches being enabled simultaneously. This eliminates signal disruption during switching.

The control input, S, tolerates input drive signals up to 5.5V, independent of supply voltage.

### Connection Diagram

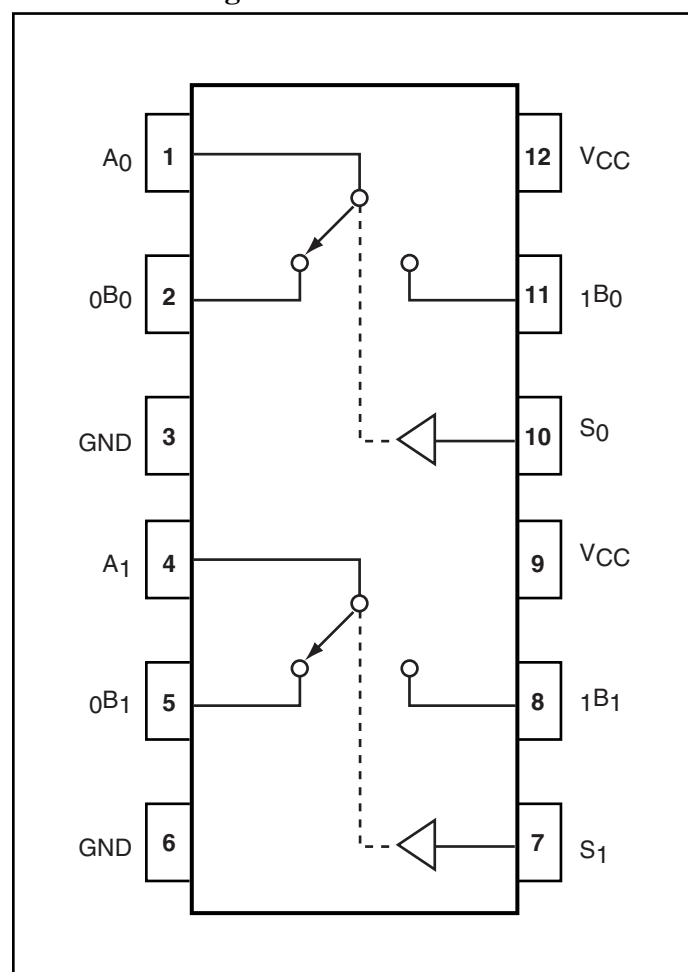

### Absolute Maximum Ratings<sup>(1)</sup>

Supply Voltage $V_{CC}$ .....	-0.5V to +7V
DC Switch Voltage ( $V_S$ ) <sup>(2)</sup> .....	-0.5V to $V_{CC} + 0.5V$
DC Input Voltage ( $V_{IN}$ ) <sup>(2)</sup> .....	-0.5V to +7.0V
DC Output Current ( $V_{OUT}$ ) .....	128mA
DC $V_{CC}$ or Ground Current ( $I_{CC}/I_{GND}$ ) .....	$\pm 100mA$
Storage Temperature Range ( $T_{STG}$ ) .....	-65°C to +150°C
Junction Temperature under Bias ( $T_J$ ) .....	150°C
Junction Lead Temperature ( $T_L$ )	
(Soldering, 10 seconds) .....	260°C
Power Dissipation ( $P_D$ ) @ +85°C .....	180mW

### Recommended Operating Conditions<sup>(3)</sup>

Supply Voltage Operating ( $V_{CC}$ ) .....	1.65V to 5.5V
Control Input Voltage ( $V_{IN}$ ) .....	0V to $V_{CC}$
Switch Input Voltage ( $V_{IN}$ ) .....	0V to $V_{CC}$
Output Voltage ( $V_{OUT}$ ) .....	0V to $V_{CC}$
Operating Temperature ( $T_A$ ) .....	-40°C to +85°C
Input Rise and Fall Time ( $t_r, t_f$ )	
Control Input $V_{CC} = 2.3V - 3.6V$ .....	0ns/V to 10ns/V
Control Input $V_{CC} = 4.5V - 5.5V$ .....	0ns/V to 5ns/V
Thermal Resistance ( $\theta_{JA}$ ) .....	350°C/W

#### Notes:

1. Absolute Maximum Ratings” may cause permanent damage to the device. This is a stress only rating and operation of the device at these or any other conditions beyond those indicated in the operational sections of this specification is not implied.
2. The input and output negative voltage ratings may be exceeded if the input and output diode current ratings are observed.
3. . . . . Control input must be held HIGH or LOW; it must not float.

### DC Electrical Characteristics (Over the Operating temperature range, $T_A = -40^\circ C$ to $85^\circ C$ )

Parameters	Description	Test Conditions	Supply Voltage	Temp	Min.	Typ.	Max.	Units	
$V_{IAR}$	Analog Input Signal Range		$V_{CC}$	$T_A = 25^\circ C$ & -40°C to 85°C	0		$V_{CC}$	V	
$R_{ON}$	On-Resistance <sup>(4)</sup>	$I_O = 30mA, V_{IN} = 0V$	4.5V	$T_A = 25^\circ C$		4	6	$\Omega$	
		$I_O = -30mA, V_{IN} = 2.4V$				5	8		
		$I_O = -30mA, V_{IN} = 4.5V$				8	13		
$R_{ON}$		$I_O = 30mA, V_{IN} = 0V$	4.5V	$T_A = -40^\circ C$ to 85°C					6
		$I_O = -30mA, V_{IN} = 2.4V$					8		
		$I_O = -30mA, V_{IN} = 4.5V$					13		
$R_{ON}$		$I_O = 24mA, V_{IN} = 0V$	3.0V	$T_A = 25^\circ C$		5	8		
		$I_O = -24mA, V_{IN} = 3.0V$				12	19		
$R_{ON}$		$I_O = 24mA, V_{IN} = 0V$	3.0V	$T_A = -40^\circ C$ to 85°C					8
		$I_O = -24mA, V_{IN} = 3.0V$					19		
$R_{ON}$		$I_O = 24mA, V_{IN} = 0V$	2.3V	$T_A = 25^\circ C$		6	9		
		$I_O = -24mA, V_{IN} = 2.3V$				16	24		
$R_{ON}$	$I_O = 24mA, V_{IN} = 0V$	2.3V	$T_A = -40^\circ C$ to 85°C				9		
	$I_O = -24mA, V_{IN} = 2.4V$					24			
$R_{ON}$	$I_O = 24mA, V_{IN} = 0V$	1.65V	$T_A = 25^\circ C$		8	12			
	$I_O = -24mA, V_{IN} = 1.65V$				27	39			
$R_{ON}$	$I_O = 24mA, V_{IN} = 0V$	1.65V	$T_A = -40^\circ C$ to 85°C				12		
	$I_O = -24mA, V_{IN} = 1.65V$					39			

**DC Electrical Characteristics** (Over the Operating temperature range,  $T_A = -40^\circ\text{C}$  to  $85^\circ\text{C}$ ) (continued)

Parameters	Description	Test Conditions	Supply Voltage	Temp	Min.	Typ.	Max.	Units
$\Delta R_{ON}$	On-Resistance Match Between Channels <sup>(4, 5, 6)</sup>	$I_A = -30\text{mA}$ , $V_{BN} = 3.15\text{V}$	4.5V	$T_A = 25^\circ\text{C}$		0.15		$\Omega$
		$I_A = -24\text{mA}$ , $V_{BN} = 2.1\text{V}$	3.0V			0.2		
		$I_A = -8\text{mA}$ , $V_{BN} = 1.6\text{V}$	2.3V			0.3		
		$I_A = -4\text{mA}$ , $V_{BN} = 1.15\text{V}$	1.65V			0.3		
$R_{ONF}$	On-Resistance Flatness <sup>(4, 5, 7)</sup>	$I_A = -30\text{mA}$ , $0 \leq V_{BN} \leq V_{CC}$	5.0V	$T_A = 25^\circ\text{C}$		6		$\Omega$
		$I_A = -24\text{mA}$ , $0 \leq V_{BN} \leq V_{CC}$	3.3V			12		
		$I_A = -8\text{mA}$ , $0 \leq V_{BN} \leq V_{CC}$	2.5V			22		
		$I_A = -4\text{mA}$ , $0 \leq V_{BN} \leq V_{CC}$	1.8V			90		
$V_{IH}$	Input High Voltage	Logic High Level	$V_{CC} = 1.65\text{V}$ to $1.95\text{V}$	$T_A = -40^\circ\text{C}$ to $85^\circ\text{C}$	0.75 $V_{CC}$			V
		$V_{CC} = 2.3\text{V}$ to $5.5\text{V}$	0.7 $V_{CC}$					
$V_{IL}$	Input Low Voltage	Logic LowLevel	$V_{CC} = 1.65\text{V}$ to $1.95\text{V}$					
			$V_{CC} = 2.3\text{V}$ to $5.5\text{V}$					
	Input Leakage Current	$0 \leq V_{IN} \leq 5.5\text{V}$	$V_{CC} \leq 0\text{V} \leq 5.5\text{V}$	$T_A = 25^\circ\text{C}$			$\pm 0.1$	$\mu\text{A}$
				$T_A = -40^\circ\text{C}$ to $85^\circ\text{C}$			$\pm 1.0$	
$I_{OFF}$	OFF State Leakage Current	$0 \leq V_{IN} \leq 5.5\text{V}$	$V_{CC} \leq 1.65\text{V} \leq 5.5\text{V}$	$T_A = 25^\circ\text{C}$			$\pm 0.1$	
				$T_A = -40^\circ\text{C}$ to $85^\circ\text{C}$			$\pm 10$	
$I_{CC}$	Quiescent Supply Current	All Channels ON or OFF, $V_{IN} = V_{CC}$ or GND, $I_{OUT} = 0$	$V_{CC} = 5.5\text{V}$	$T_A = 25^\circ\text{C}$			2	
				$T_A = -40^\circ\text{C}$ to $85^\circ\text{C}$			20	

**Notes:**

4. Measured by voltage drop between A and B pins at the indicated current through the device. On-Resistance is determined by the lower of the voltages on two ports (A or B).
5. Parameter is characterized but not tested in production.
6.  $\Delta R_{ON} = R_{ON} \text{ max} - R_{ON} \text{ min.}$  measured at identical  $V_{CC}$ , temperature and voltage levels.
7. Flatness is defined as difference between maximum and minimum value of On-Resistance over the specified range of conditions.
8. Guaranteed by design.

**Capacitance<sup>(12)</sup>**

Parameters	Description	Test Conditions	Supply Voltage	Temp	Min.	Typ.	Max.	Units
$C_{IN}$	Control Input		$V_{CC} = 5.0\text{V}$	$T_A = 25^\circ\text{C}$		2.3		pF
$C_{IO-B}$	For B Port, Switch OFF	$f = 1 \text{ MHz}^{(12)}$				6.5		
$C_{IOA-ON}$	For A Port, Switch ON					18.5		

### Switch and AC Characteristics

Parameters	Description	Test Conditions	Supply Voltage	Temp	Min.	Typ.	Max.	Units
t <sub>PLH</sub> t <sub>PHL</sub>	Propagation Delay: A to Bn	See test circuit diagram 1 and 2 V <sub>I</sub> Open <sup>(10)</sup>	V <sub>CC</sub> = 2.3V to 2.7V	T <sub>A</sub> = 25°C & -40°C to 85°C		1.2		
			V <sub>CC</sub> = 3.0V to 3.6V			0.8		
			V <sub>CC</sub> = 4.5V to 5.5V			0.3		
t <sub>PZL</sub> t <sub>PZH</sub>	Output Enable Turn ON Time: A to Bn	See test circuit diagram 1 and 2 V <sub>I</sub> = 2 V <sub>CC</sub> for t <sub>PZL</sub> , V <sub>I</sub> = 0V for t <sub>PZH</sub>	V <sub>CC</sub> = 1.65V to 1.95V	T <sub>A</sub> = 25°C	7		23	
			V <sub>CC</sub> = 2.3V to 2.7V		3.5		13	
			V <sub>CC</sub> = 3.0V to 3.6V		2.5		6.9	
			V <sub>CC</sub> = 4.5V to 5.5V		1.7		5.2	
t <sub>PZL</sub> t <sub>PZH</sub>	Output Enable Turn ON Time: A to Bn	See test circuit diagram 1 and 2 V <sub>I</sub> = 2 V <sub>CC</sub> for t <sub>PZL</sub> , V <sub>I</sub> = 0V for t <sub>PZH</sub>	V <sub>CC</sub> = 2.5V	T <sub>A</sub> = 25°C & -40°C to 85°C			24	
			V <sub>CC</sub> = 3.3V				14	
			V <sub>CC</sub> = 3.0V to 3.6V				7.6	
			V <sub>CC</sub> = 4.5V to 5.5V				5.7	
t <sub>PLZ</sub> t <sub>PHZ</sub>	Output Disable-Turn OFF Time: A to Bn	See test circuit diagram 1 and 2 V <sub>I</sub> = 2 V <sub>CC</sub> for t <sub>PLZ</sub> , V <sub>I</sub> = 0V for t <sub>PHZ</sub>	V <sub>CC</sub> = 1.65V to 1.95V	T <sub>A</sub> = 25°C	3		12.5	
			V <sub>CC</sub> = 2.3V to 2.7V		2		7	
			V <sub>CC</sub> = 3.0V to 3.6V		1.5		5	
			V <sub>CC</sub> = 4.5V to 5.5V		0.8		3.5	
t <sub>PLZ</sub> t <sub>PHZ</sub>	Output Disable-Turn OFF Time: A to Bn	See test circuit diagram 1 and 2 V <sub>I</sub> = 2 V <sub>CC</sub> for t <sub>PLZ</sub> , V <sub>I</sub> = 0V for t <sub>PHZ</sub>	V <sub>CC</sub> = 2.5V	T <sub>A</sub> = 25°C & -40°C to 85°C			13	
			V <sub>CC</sub> = 3.3V				7.5	
			V <sub>CC</sub> = 3.0V to 3.6V				5.3	
			V <sub>CC</sub> = 4.5V to 5.5V				3.8	
t <sub>BM</sub>	Break Before Make Time	See Test Circuit diagram 9. <sup>(9)</sup>	V <sub>CC</sub> = 2.5V	T <sub>A</sub> = 25°C & -40°C to 85°C	0.5			
			V <sub>CC</sub> = 3.3V		0.5			
			V <sub>CC</sub> = 3.0V to 3.6V		0.5			
			V <sub>CC</sub> = 4.5V to 5.5V		0.5			
Q	Charge Injection	C <sub>L</sub> = 0.1nF, V <sub>GEN</sub> = 0V, R <sub>GEN</sub> = 0Ω, See test circuit 4	V <sub>CC</sub> = 5.0V	T <sub>A</sub> = 25°C		7		pC
			V <sub>CC</sub> = 3.3V			3		
O <sub>IRR</sub>	Off Isolation	R <sub>L</sub> = 50Ω, V <sub>GEN</sub> = 0V, R <sub>GEN</sub> = 0Ω, See test circuit 5 <sup>(11)</sup>	V <sub>CC</sub> = 1.65V to 5.5V	T <sub>A</sub> = 25°C		-57		dB
X <sub>TALK</sub>	Crosstalk Isolation	See test circuit 6	V <sub>CC</sub> = 1.65V to 5.5V	T <sub>A</sub> = 25°C		-54		
f <sub>3dB</sub>	-3dB Bandwidth	See test circuit 9	V <sub>CC</sub> = 1.65V to 5.5V	T <sub>A</sub> = 25°C		250		MHz

**Notes:**

9. Guaranteed by design.
10. Guaranteed by design but not production tested. The device contributes no other propagation delay other than the RC delay of the switch On-Resistance and the 50pF load capacitance, when driven by an ideal voltage source with zero output impedance.
11. Off Isolation = 20 Log<sub>10</sub> [ V<sub>A</sub> / V<sub>Bn</sub> ] and is measured in dB.
12. T<sub>A</sub> = 25°C, f = 1MHz. Capacitance is characterized but not tested in production.

Test Circuits and Timing Diagrams

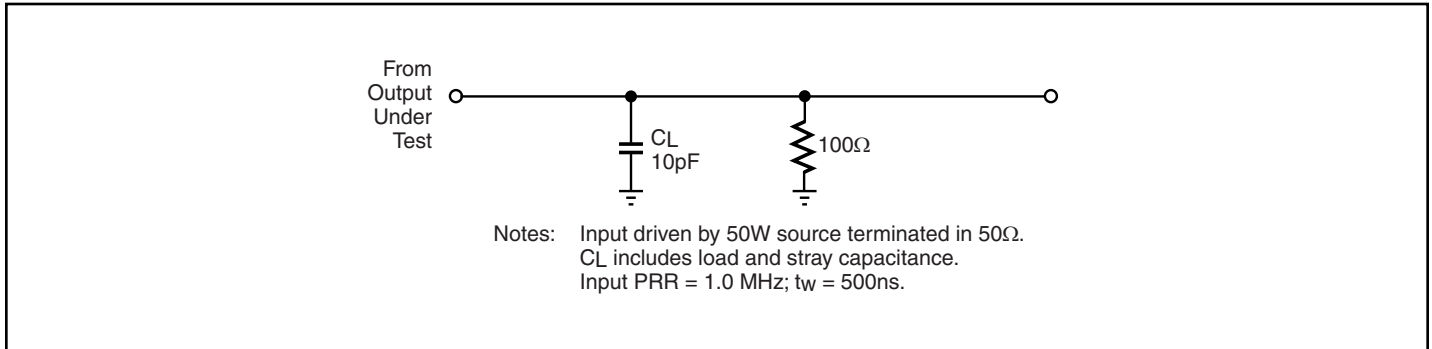

Figure 1. AC Test Circuit

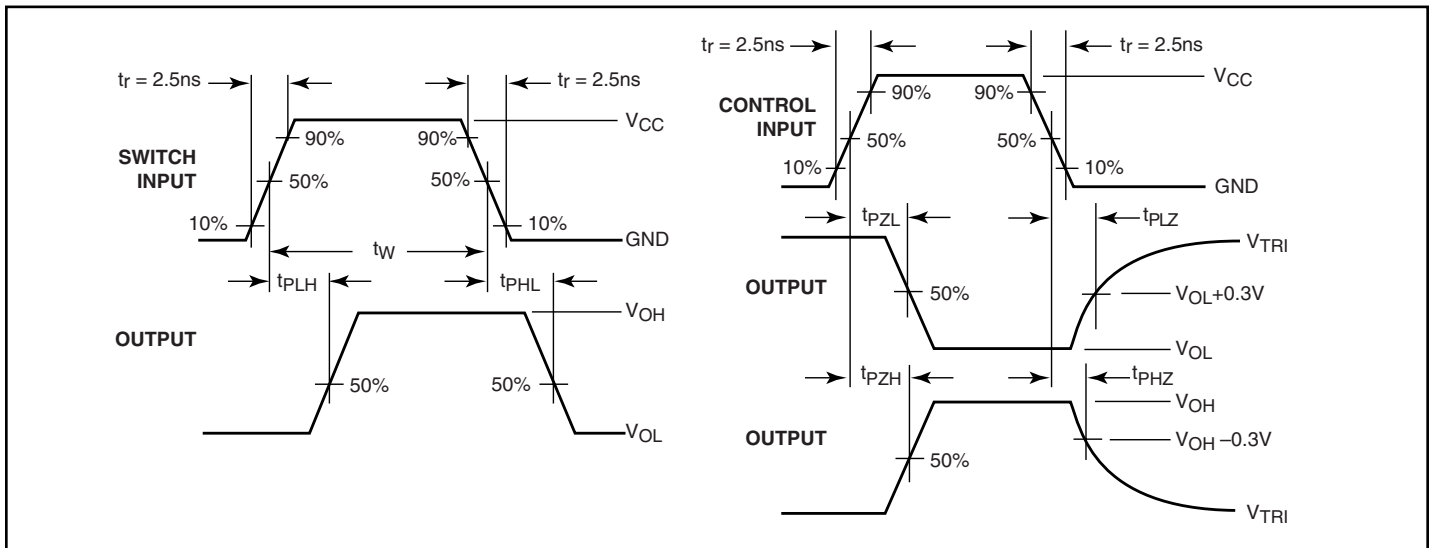

Figure 2. AC Waveforms

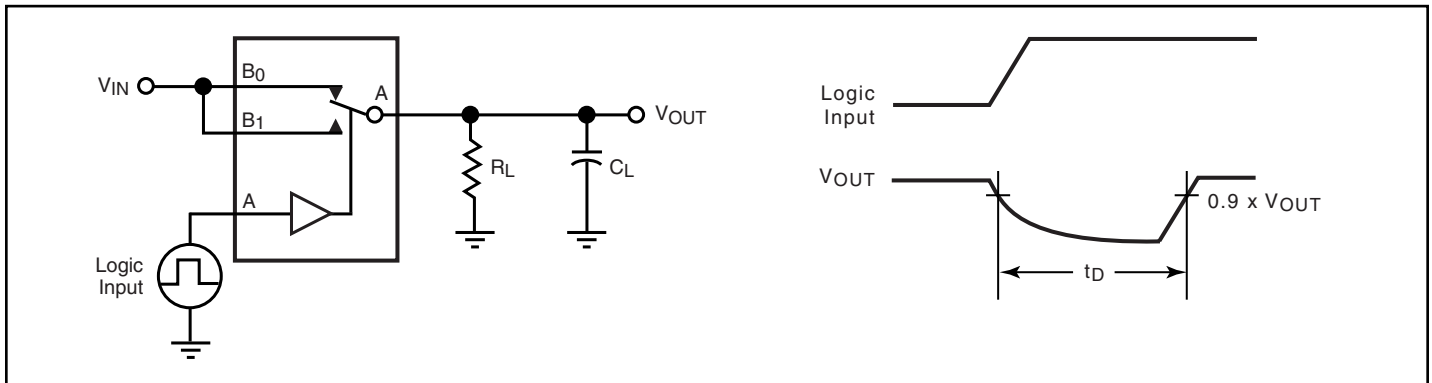

Figure 3. Break Before Make Interval Timing

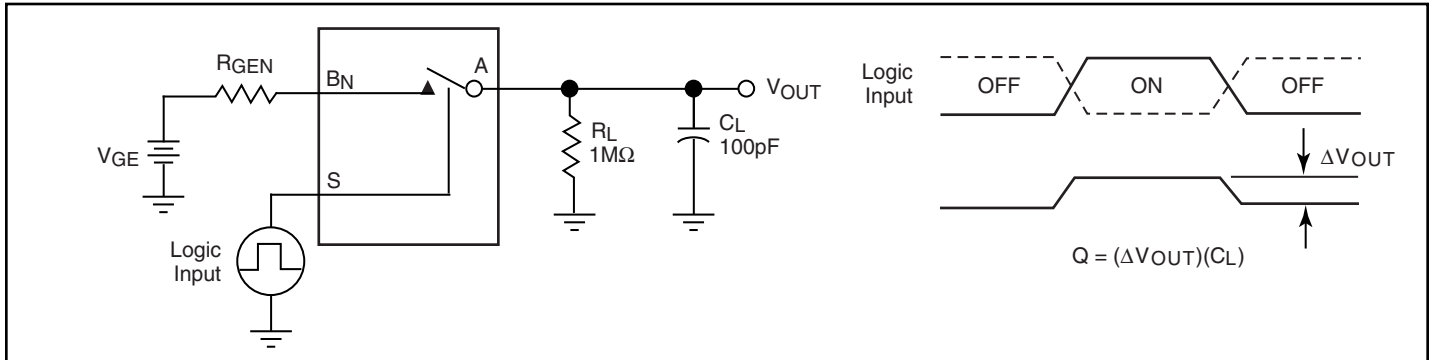

Figure 4. Charge Injection Test

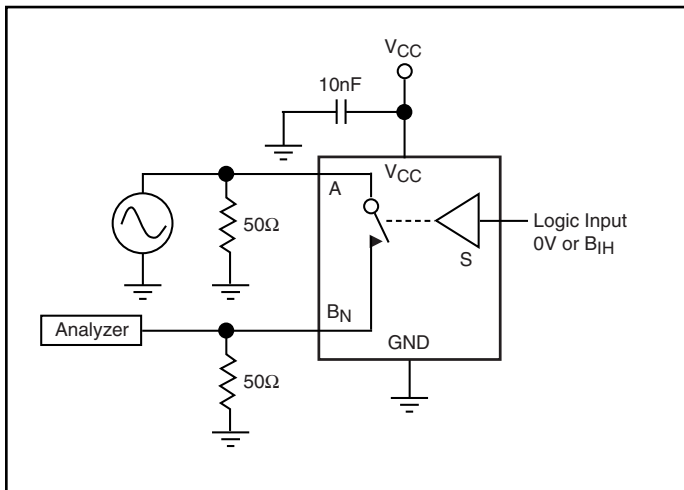

Figure 5. Off Isolation

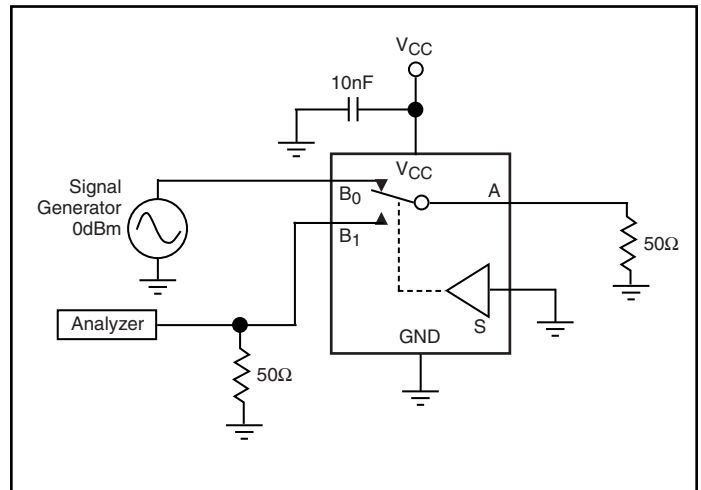

Figure 6. Crosstalk

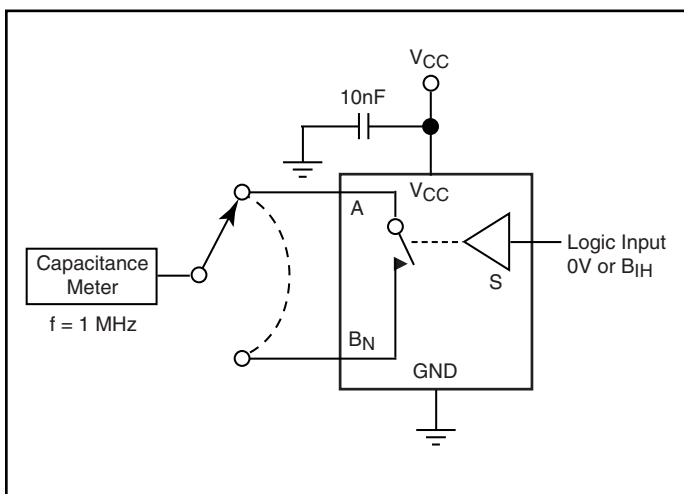

Figure 7. Channel Off Capacitance

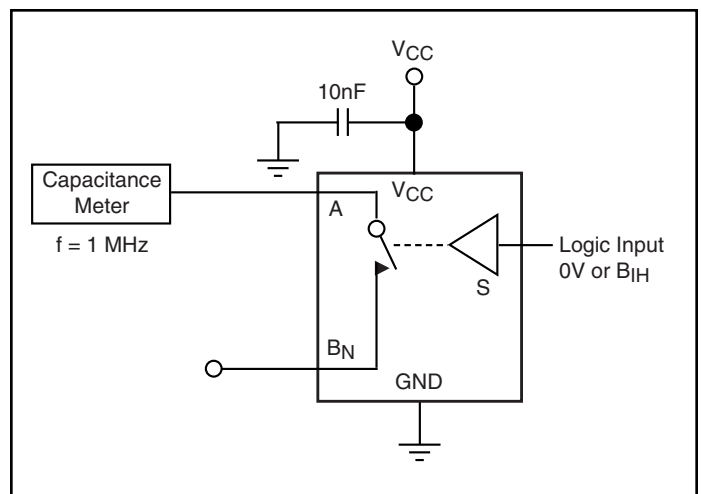

Figure 8. Channel On Capacitance

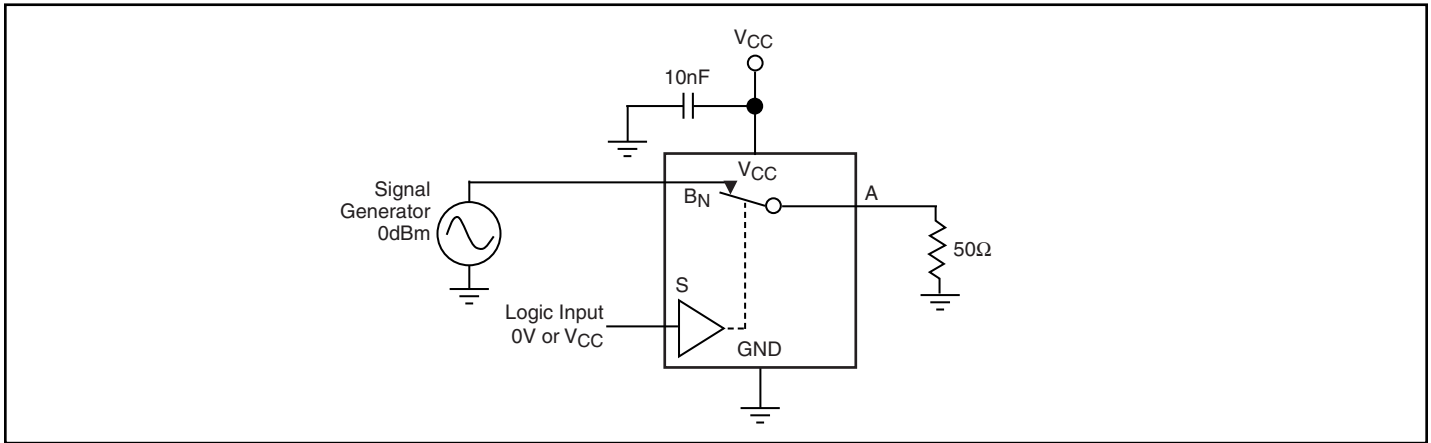
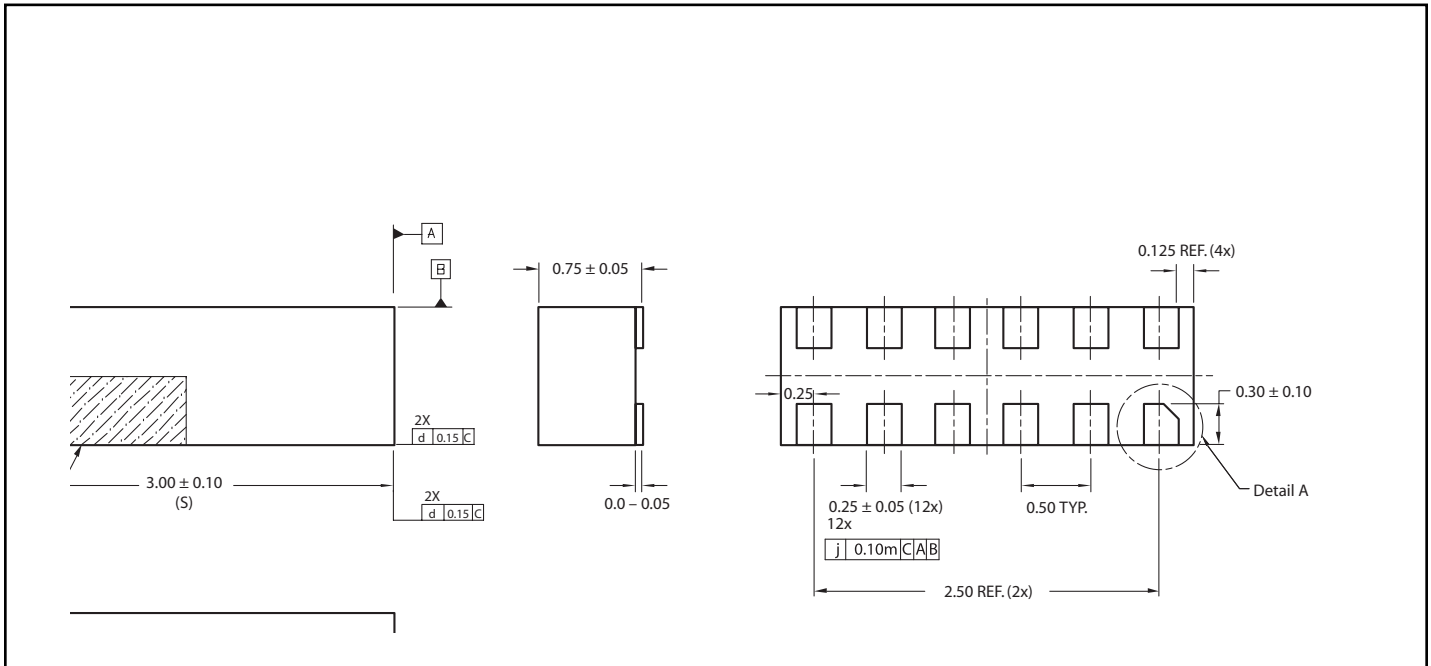

Figure 9. Bandwidth

**Packaging Mechanical : 12-contact TDFN (ZA)**



**Ordering Information**

Ordering Code	Packaging Code	Package Type	Top Mark
PI5A3158ZA <sup>(1)</sup>	ZA	12-contact TDFN	A0
PI5A3158ZAE	ZA	Pb-free & Green, 12-contact TDFN	$\bar{A}0$

**Notes:**

1. This product has always shipped as only a lead free product, but since it was introduced prior to Pericom's strategy of adding an E to all Green/Lead free parts many customers order it without the E suffix. Please migrate new designs and qualification to include the E suffix. Pericom at this point in time will continue to offer devices marked both ways, but may at a later date eliminate the non-E part number.
2. Thermal characteristics can be found on the company web site at [www.pericom.com/packaging/](http://www.pericom.com/packaging/)